

## Analysis of the Frame Strength on the Paint Mixer Machine Using ANSYS Workbench Software

Paryanto <sup>a</sup>, Anang Dwi Jayanto <sup>b,\*</sup>

<sup>a</sup>Department of Mechanical Engineering Education, Universitas Negeri Yogyakarta, Indonesia

<sup>b</sup>Department of Mechanical and Automotive Engineering, Universitas Negeri Yogyakarta, Indonesia

\*Corresponding author: [anangdwi.2019@student.uny.ac.id](mailto:anangdwi.2019@student.uny.ac.id)

### ARTICLE INFO

#### Article history:

Received 23.02.2025  
Revised 13.03.2025  
Accepted 22.03.2025

#### Keywords:

Frame strength, mixer cat machine, ansys workbench

### ABSTRACT

The era of industrialization requires humans to continuously strive to develop technology, one of which is the semi-automatic paint mixer machine. The purpose of this research is to determine the strength of the mixer machine frame and the motor mount frame of the paint mixer machine, through the analysis of von Mises stress, deformation, and safety factor. This research is a quantitative study using a descriptive method. The research design involves finite element method simulations using Ansys Workbench 2023 R1 software. Data collection techniques used are observation and documentation. Data analysis is performed using descriptive statistical techniques. The maximum von Mises stress analysis in areas 1, 2, and 3 resulted in values of 0.2975 MPa, 2.2619 MPa, and 3.4034 MPa, respectively. These results are still well below the yield strength of ASTM A36 material. This occurs around the area where the load is applied near the joint. The maximum deformation analysis in areas 1, 2, and 3 yielded results of 0.00038 mm, 0.00415 mm, and 0.0274 mm, respectively. This occurs around the area near the front edge where the load is applied away from the joint. The safety factor analysis in areas 1, 2, and 3 resulted in a value of 15. This exceeds the required safety factor, indicating that the frame is safe to withstand the applied loads.

## 1 Introduction

The industrial development in the era of industrialization has been rapid, both in industries related to production and those involved in manufacturing. PT. Nananindo Engineering is a medium-sized industry located in Modalan, Banguntapan, Bantul, Special Region of Yogyakarta. This industry operates a factory specializing in the production of motorcycle rims. The company has developed a paint mixer machine that operates automatically. The working principle of the paint mixer machine is to mix paint with thinner in the correct proportion into a paint reservoir, then operate the machine by pressing a button, causing the machine to stir the paint. The design of the construction requires analysis to determine whether the structural strength of the frame design is safe and meets the required usage needs. The analysis is performed through stress and deformation testing [1].

The analysis of the structural strength of the frame can be conducted using either simulation methods or experimental methods. However, due to the numerous parameters that need to be considered, such as the need for test materials and the limitations associated with using experimental methods, analysis through simulation can be performed more easily and accurately [2]. Additionally, experimental methods require high costs [3].

Analysis using software based on the finite element method produces results that are not significantly different from those obtained through actual experimental research. Moreover, software is used to accelerate the planning process in order to determine the strength of a construction [4]. Such analyses have been widely conducted by researchers, and the results are used as guidelines to assess the safety of a product design [5].

In this study, a simulation method was used with the assistance of Ansys Workbench 2023 R1 software. The finite element method was employed to determine the structural strength of the paint mixer machine frame against the loads from the components of the paint mixer machine mechanism. This includes the results of von Mises stress, deformation, and safety factor (safety factor) of the paint mixer machine frame and the motor mount frame of the paint mixer machine that has been designed.

## 2 Method

The type of research conducted is quantitative with a descriptive method, aimed at describing the properties of an object during testing and identifying the causes of specific phenomena in the object being tested. In the descriptive research method, a document approach (content analysis) is used, where the researcher collects data and information through the results of the conducted tests [6].

### 2.1 Tools and materials

The tools used in this study include a computer, software Ansys Workbench 2023 R1, and software Autodesk Inventor Professional 2022. The computer specifications:

- Processor Type: Intel Core i5-9300H Quad-core
- Processor Memory: 8GB DDR4 RAM, 256GB PCIe SSD
- VGA: NVIDIA GeForce GTX 1660 Ti
- VGA Memory: 6GB GDDR6

The materials used in this finite element method simulation study are paint mixers as shown in Figure.2 with the structural properties of ASTM A36 steel plate that is shown in Table 1.

**Tabel 1.** Structural Properties ASTM A36 steel plate

| Material Properties    | Value                  |
|------------------------|------------------------|
| Density                | 7899 kg/m <sup>3</sup> |
| Young modulus          | 2000 GPa               |
| Poisson ratio          | 0.26                   |
| Tensile yield strength | 250 Mpa                |

### 2.2 Research Procedure

The research procedure includes simulation pre-processing, mesh convergence, and simulation process.

#### a. Simulation pre-processing

Numerical simulations were performed using Ansys Workbench 2023 R1 software. Before the simulation, the mass of the components of the paint mixer machine mechanism was determined. This mass was assumed based on the weight of the components produced by the manufacturer and the mass of the paint mixer design components obtained from Autodesk Inventor Professional 2022 software using the mass properties feature. This allowed the

determination of the load on the components of the paint mixer machine frame. The components and their masses are presented in Table 2.

**Table 2.** Component Masses of the Paint Mixer Machine Section

| No | Components              | Descriptions                            | Mass (kg) |
|----|-------------------------|---|-----------|
| 1  | Paint mixer motor       | Ac motor 0,25 Hp                        | 9         |
| 2  | Arbor connector         | Mandrel arbor connector M10, Shaft 8 mm | 0.04      |
| 3  | Drill chunks            | Drill head 10 mm, chunk 10 mm           | 0.16      |
| 4  | Motor paint mixer frame | Steel, carbon                           | 2.4       |
| 5  | Thread                  | Steel carbon 9 mm                       | 0.42      |
| 6  | Shaft (x 2)             | Stainless steel 9 mm                    | 0.542     |
| 7  | Linear bearing block    | SC12LUU 12 mm, Aluminum                 | 0.4       |
| 8  | Linear shaft support    | SHF12, Aluminum                         | 0.12      |
| 9  | Up support bearing      | Steel, carbon                           | 0.144     |
| 10 | Down support bearing    | Aluminum 6061                           | 0.12      |
| 11 | Bearing                 | SKF 6201                                | 0.092     |
| 12 | Housing                 | Aluminum 6061                           | 0.22      |
| 13 | Nut housing             | Brass, soft yellow                      | 0.182     |
| 14 | Threaded shaft coupling | Steel, carbon                           | 0.053     |
| 15 | Threaded drive motor    | Nema motor 23                           | 1.3       |
| 16 | Paint stirrer shaft     | Polyurethane 8 mm diameter              | 0.5       |

#### b. Mesh convergence

The mesh size convergence test was conducted using Ansys Workbench 2023 R1 software. The test involved varying the element size of the mesh, with the software indicating the optimal mesh value to be used. The mesh changes were performed until no significant change in stress values occurred [7].

#### c. Simulation process

The finite element method simulation was performed using Ansys Workbench 2023 R1 software.

### 2.3 Data Collection Technique

The data collection techniques used are observation and documentation. Observation is employed to determine the placement of the components of the paint mixer machine mechanism on the paint mixer machine frame and the motor mount frame of the paint mixer machine. Meanwhile, documentation is used to show the areas that are subjected to loading from the components of the paint mixer machine mechanism. The simulation data analysis includes von Mises stress, deformation, and safety factor. The test results are then described using numerical values, which are entered into tables displaying the simulation results for both the paint mixer machine frame and the motor mount frame of the paint mixer machine.

## 3 Result and discussion

The simulation results conducted using the finite element method (FEM) through Ansys Workbench 2023 R1 provide valuable insights into the structural integrity of the paint mixer machine frame. The key parameters assessed include von Mises stress, deformation, and safety factor across different areas of the frame.

### 3.1 3D CAD design

The 3D CAD design was created using Autodesk Inventor Professional 2022 software. The dimensions of the paint mixer machine frame design can be seen in Figure 1.



**Table 3.** Mesh convergence

| No | Mesh (mm) | Stress (Mpa) |
|----|-----------|--------------|
| 1  | 8         | 1.6023       |
| 2  | 9         | 1.6605       |
| 3  | 10        | 1.6065       |
| 4  | 11        | 1.6691       |
| 5  | 12        | 1.7076       |
| 6  | 13        | 1.4612       |
| 7  | 14        | 1.5841       |
| 8  | 15        | 1.6650       |
| 9  | 16        | 1.5432       |
| 10 | 17        | 1.7494       |

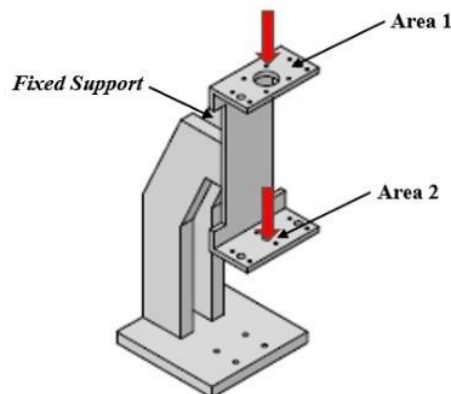
For the paint mixer machine frame, the test results were quite stable with mesh sizes ranging from 8 mm to 11 mm, while for the motor mount frame of the paint mixer machine, the test results were stable with mesh sizes ranging from 10 mm to 12 mm. The mesh size used for simulating the paint mixer machine frame was 8 mm, and for the motor mount frame of the paint mixer machine, a mesh size of 10 mm was used.

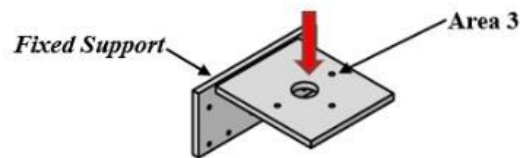
**Table 4.** Mesh Convergence Test Results for the Motor Mount Frame

| No | Mesh (mm) | Stress (Mpa) |
|----|-----------|--------------|
| 1  | 8         | 3.7184       |
| 2  | 9         | 3.6488       |
| 3  | 10        | 3.5778       |
| 4  | 11        | 3.5550       |
| 5  | 12        | 3.5748       |
| 6  | 13        | 3.6269       |
| 7  | 14        | 3.5079       |
| 8  | 15        | 3.5274       |
| 9  | 16        | 3.3772       |
| 10 | 17        | 3.4318       |

### 3.4 Simulation

The paint mixer machine frame and the motor mount frame for the paint mixer machine receive evenly distributed loads in each area where the components of the paint mixer machine mechanism are placed, as shown in Table 2. The supports in each loading area are fixed supports. The support areas and the placement of the paint mixer machine mechanism components on the paint mixer machine frame and the motor mount frame for the paint mixer machine can be seen in Figure 3 and 4.

**Figure 3.** Loading on the Paint Mixer Machine Frame



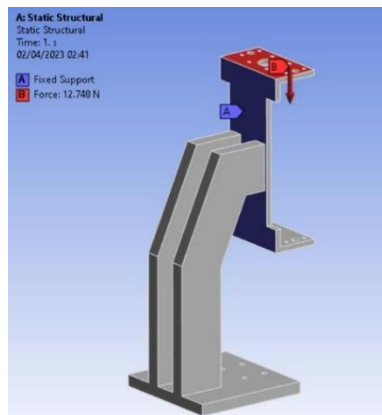
**Figure 4.** Loading on the Motor Mount Frame

### 3.5 Results of Von Mises Stress Testing

The von Mises stress results for the frame in areas 1, 2, and 3 are still well below the yield strength of the material used, which is ASTM A36 with a yield strength of 250 MPa.

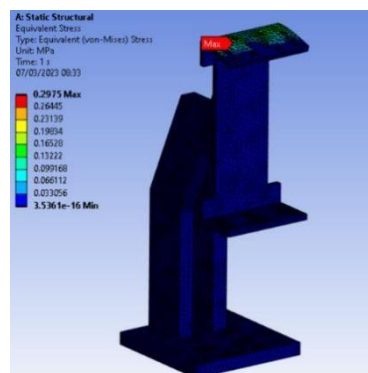
#### a. Results of Testing for Area 1

The simulation using the finite element method with Ansys Workbench 2023 R1 was conducted on Area 1 of the paint mixer machine frame, as shown in Figure 7. In this area, there is a component of the drive motor screw, with the mass of the paint mixer machine mechanism components shown in Table 2. The total load applied to this area is 1.3 kg or 12.748 N. The element type used is the tetrahedron method, with a mesh size of 8 mm consisting of 55,513 elements. The placement of the fixed support and force in Area 1 is shown in Figure 5.

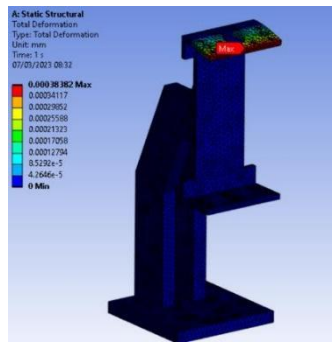


**Figure 5.** The placement of the fixed support

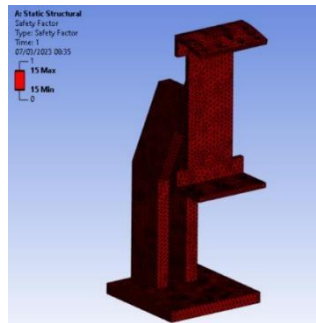
The results of the testing for Area 1 of the paint mixer machine frame show that the maximum von mises stress is 0.2975 MPa, the maximum deformation is 0.00038 mm, and the safety factor is 15. These results indicate that the structure in Area 1 is well within the material's safety limits, with a safety factor significantly higher than the required threshold, suggesting that the design is safe under the applied loads. The results of the testing for Area 1 of the paint mixer machine frame are shown in Figures 6, 7, and 8.



**Figure 6.** Von Mises Stress Simulation Results for Area 1 Testing



**Figure 7.** Deformation Simulation Results for Area 1 Testing

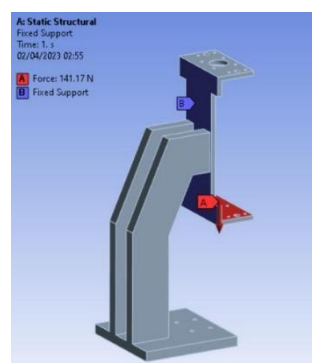


**Figure 8.** Safety Factor Simulation Results for Area 1 Testing

Based on the simulation results shown in Figure 10, it can be observed that the maximum von Mises stress occurs around the area where the load is applied, near the joint in Area 1.

#### b. Results of Testing for Area 2

The simulation using the finite element method on Area 2 of the paint mixer machine frame, as shown in Figure 3. This area contains components such as the paint mixer motor drive, arbor connector, drill head, motor mount frame, screw, shaft, linear bearing block, linear shaft support, upper bearing support, lower bearing support, bearing, housing, nut housing, screw shaft coupling, and the paint mixer stirrer. The mass of these paint mixer machine mechanism components is shown in Table 2. The total load applied to this area is 14.395 kg or 141.17 N. The element type used is the tetrahedron method, with an 8 mm mesh size consisting of 55,502 elements. The placement of the fixed support and the force applied to Area 2 is shown in Figure 9.



**Figure 9.** Fixed Support and Force in Area 2

The results of the testing for Area 2 of the paint mixer machine frame are shown in Figures 10, 11, and 12.

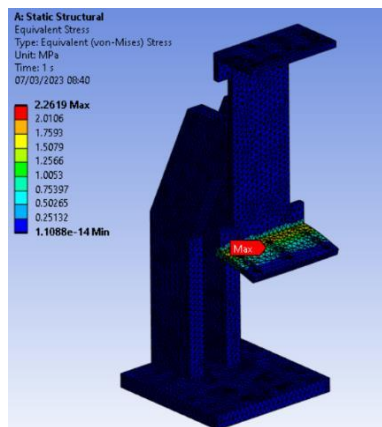


Figure 10. Von Mises Stress Simulation Results for Area 2

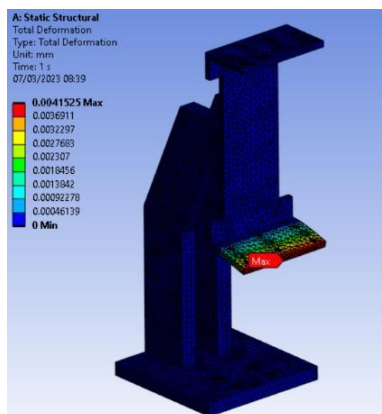


Figure 11. Deformation for Area 2

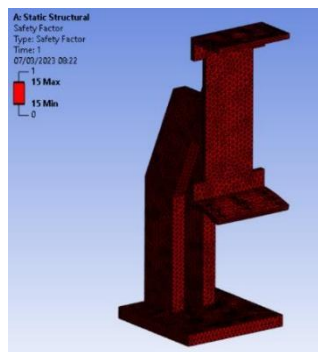


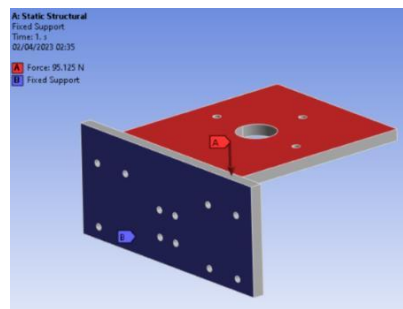
Figure 12. Safety Factor for Area 2

Based on the simulation results shown in Figure 10, it can be observed that the maximum von Mises stress occurs around the area where the load is applied, near the joint in Area 2.

### c. Results of Testing for Area 3

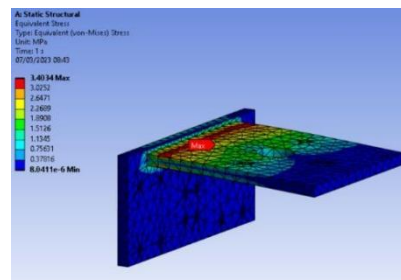
The simulation using the finite element method with Ansys Workbench 2023 R1 was conducted on Area 3 of the motor mount frame for the paint mixer machine, as shown in Figure 8. This area contains components such as the motor drive for the paint mixer, arbor connector, drill head, and paint stirrer shaft. The mass of these paint mixer machine mechanism components is shown in Table 2. The total load applied to this area is 9.7 kg or 95.125 N. The element type used is the tetrahedron method, with a mesh size of 10 mm consisting of 3,852 elements. The placement of the fixed support and force in Area 3 is shown in Figure 13.



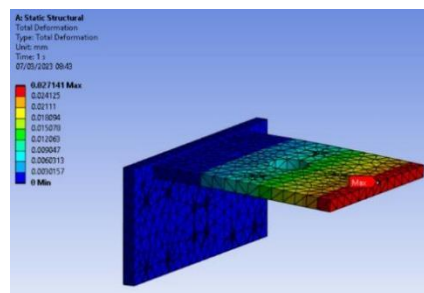


**Figure 13.** Fixed Support and Force in Area 3

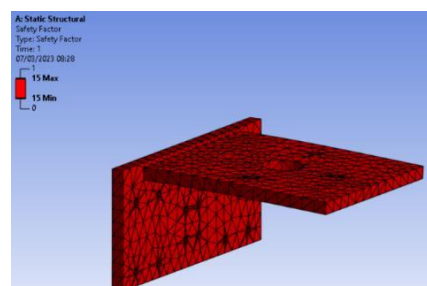
The results of the testing for Area 3 of the paint mixer machine frame show that the maximum von mises stress is 3.4034 MPa, the maximum deformation is 0.0274 mm, and the safety factor is 15. These results indicate that the structure in Area 3 is well within the material's safety limits, as the safety factor is significantly above the required threshold. The results for Area 3 are shown in Figures 14, 15, and 16.



**Figure 14.** Von Mises Stress for Area 3 Testing



**Figure 15.** Deformation for Area 3



**Figure 16.** Safety Factor Area 3

Based on the simulation results shown in Figure 15, it can be observed that the maximum von Mises stress occurs around the area where the load is applied, near the joint in Area 3.

The deformation results for the frames in Areas 1, 2, and 3 show relatively small values: 0.00038 mm, 0.00415 mm, and 0.00415 mm, respectively. These results indicate that the material deforms minimally under load, which suggests it is relatively strong. As explained by Wibawa *et al.*, 2020, the stronger the material, the lower its deformation. The safety factor for the tests in Areas 1, 2, and 3 is 15 for each, which indicates that the design of the paint mixer machine frame is safe and can withstand the loads from the mixer components. The safety factor is a parameter used in design to express the safety of a system based on its minimum dimensions, with a safety factor above 1 (one). For the frame, which is subjected to static loads,

a safety factor range between 1.25 and 2 is typically used. The testing result is presented in Table 5

**Table 5.** Results of Testing for Area 1, 2, and 3

| Area   | Von Mises Stress | Deformation | Safety Factor |
|--------|------------------|-------------|---------------|
| Area 1 | 0.2975           | 0.00038     | 15            |
| Area 2 | 2.2619           | 0.00415     | 15            |
| Area 3 | 3.4034           | 0.0274      | 15            |

#### 4 Conclusion

Based on the finite element analysis (FEA) conducted using Ansys Workbench 2023 R1, the following conclusions can be drawn:

##### a. Structural Integrity

The paint mixer machine frame, as well as the motor mounting frame, were found to exhibit von Mises stress values that are significantly lower than the yield strength of the material (ASTM A36 steel). This confirms that the frame is structurally sound and can withstand the applied loads without risk of yielding.

##### b. Minimal Deformation

The deformation results were very small across all analyzed areas (Area 1: 0.00038 mm, Area 2: 0.00415 mm, Area 3: 0.0274 mm), indicating that the frames maintain their shape and integrity under the operational load. The results support the notion that the material is sufficiently strong to resist significant deflection.

##### c. Safety Factor

The safety factor for all areas was calculated to be 15, far exceeding the required minimum for static loads. This high safety margin indicates that the frame design is highly reliable and capable of handling operational stresses well beyond expected conditions.

##### d. Design Adequacy

The analysis demonstrates that the design of the paint mixer machine frame is both efficient and safe. The frame provides ample strength and durability to endure long-term use in manufacturing processes.

In conclusion, the paint mixer machine frame is well-designed to meet the required performance standards and can safely support the load from the mixer components. The results from the simulations indicate that the design has sufficient strength, minimal deformation, and an excellent safety factor, ensuring both reliability and longevity of the machine in practical use

#### Acknowledgements

The author is grateful to the Department of Mechanical Engineering and Automotive, Universitas Negeri Yogyakarta for all the support extended in conducting research

#### Conflicts of Interest

The authors no conflict of interest.

#### References

- [1] P. M. Ceper, S. H. D. Hastuti, W. A. Ramadhani, and N. Mulyaningsih, "ANALISIS KEKUATAN PADA RANGKA SEPEDA MOTOR LISTRIK DENGAN METODE ELEMEN HINGGA," *JURNAL FOUNDRY*, 2022, [Online]. Available: <https://api.semanticscholar.org/CorpusID:269418023>

- [2] Saifullah, Ali and Mamungkas, and Mohamad Irkham, “Analisis pembebanan vertikal pada frame sepeda menggunakan metode elemen hingga dengan bantuan ansys,” *Seminar Nasional Teknologi dan Rekayasa (SENTRA)*, pp. 145–150, 2020.
- [3] Sahril Afandi Sitompul and Abdul Hanafi, “ANALISIS TABRAK BURUNG PADA LEADING EDGE DENGAN METODE ELEMEN HINGGA,” *JTK: JURNAL TEKNOLOGI KEDIRGANTARAAN*, vol. 2, no. 2, Sep. 2017.
- [4] E. Sutikno, “Analisis Tegangan Akibat Pembebanan Statis Pada Desain Carbody Tec Railbus Dengan Metode Elemen Hingga,” *Jurnal Rekayasa Mesin Universitas Brawijaya*, vol. 2, no. 1, 2011.
- [5] E. Prasetyo, R. Hermawan, M. N. I. Ridho, I. I. Hajar, H. Hariri, and E. A. Pane, “Analisis Kekuatan Rangka Pada Mesin Transverse Ducting Flange (TDF) Menggunakan Software Solidworks,” *Rekayasa*, vol. 13, no. 3, pp. 299–306, Dec. 2020, doi: 10.21107/rekayasa.v13i3.8872.
- [6] Ma’ruf Abdullah, *Metode Penelitian Kuantitatif*. Yogyakarta: Aswaja Pressindo, 2015.
- [7] R. Ismail, F. A. Sitanggang, and M. Ariyanto, “Analisis Kekuatan Struktur Wreable Elbow Exoskeleton untuk Penderita Kelumpuhan Gerak Siku Menggunakan Finite Element Method (FEM),” *ROTASI*, vol. 21, no. 3, p. 193, Aug. 2019, doi: 10.14710/rotasi.21.3.193-199.
- [8] L. A. N. Wibawa, “DESAIN DAN ANALISIS TEGANGAN STRUKTUR CRANE KAPASITAS 10 TON MENGGUNAKAN METODE ELEMEN HINGGA,” *Jurnal Muara Sains, Teknologi, Kedokteran dan Ilmu Kesehatan*, vol. 4, no. 2, p. 201, Oct. 2020, doi: 10.24912/jmstkik.v4i2.7006.