

# FDM 3D printing application for making plate patterns on sand casting

Muhammad Royan<sup>1</sup>, Arianto Leman Soemowidagdo<sup>2,\*</sup>, Beni Tri Sasongko<sup>3</sup>, Deny Aji Pradana<sup>4</sup>

<sup>1</sup>Garuda Metalindo, North Jakarta, Jakarta 14470, Indonesia

<sup>2,3</sup>Department of Mechanical Engineering Education, Universitas Negeri Yogyakarta, Indonesia

<sup>4</sup>Small and Medium Enterprise DA Jaya, Ceper, Klaten 57465, Indonesia

E-mail: arianto\_ls@uny.ac.id \*

\* Corresponding Author

## ABSTRACT

Pattern making in sand casting requires high-level skilled workers since accuracy is the most important concern in producing good quality products. Therefore, conventional pattern-making becomes a major obstacle in developing new products, especially for complicated products as it takes over 70% of the total time in production of the foundry process. This study offers an alternative method in pattern making utilizing 3D technology with the Fuse Deposition Material (FDM) method. It consisted of three steps: planning, production, and evaluation. An intake manifold is an example product that was designed by using Computer Aided Design (CAD) and then imported to a slicer application to obtain the G codes. After the design was printed by using filament of PLA+, it was assembled to create the plate pattern that then was used to produce the intake manifold through casting. The study result shows that the FDM method of the 3D printing technology is feasible for pattern making on sand casting. Deviation and shrinkage of the casting product were still within tolerance. The largest shrinkage is 0.453 mm (1.258%).

This is an open-access article under the CC-BY-SA license.



## ARTICLE INFO

### Article history

Received

27 June 2023

Revised

31 July 2023

Accepted

31 August 2023

### Keywords

FDM

Plate Pattern

Sand Casting

3D Printing

## 1. Introduction

Casting is a process of producing components by pouring molten metal into a mould cavity and allowing it to solidify before continuing to the next stage of work [1], [2]. The casting process consists of stages which are pattern making, mould making, metal melting, pouring, and finishing [3]. However, most of the time in the casting process is spent on making patterns approximately 70%, which is dominated by patterns made of wood, resin or metal. The more complicated a component in shape and size, the longer the time to make the pattern [4]. The small and medium enterprises of the sand casting industry require 3-8 weeks to produce a product [5].

Patterns are mostly made of wood, although brass and iron patterns are also common, especially when large quantities are required [6]. Patterns are conventionally manufactured from wood and then machined. This operation requires highly skilled labour and becomes the most expensive processing step in a long spending time. Complex patterns from wood may take more lead time, while complex shapes often provide difficulties [5], [7]. In addition, wooden patterns are very sensitive to environmental conditions. Prolonged pattern storage can cause the pattern to lose its dimensional fit [8].

The quality of geometry and dimensions of a pattern is determined by the skills of the maker and the finishing process. The increasing complexity of the pattern requires workers with high skills.



Finishing and coating processes are carried out to get a good pattern surface and long durability. This has implications for the time and cost of pattern production [9].

The application of additive manufacturing to make patterns is an alternative method for developing products by casting. This technology is also known as 3D printing which only makes prototypes mainly for shape analysis, demonstration, or making moulds to produce real castings [10]. This technology can build almost any geometry with quick prototype verification and development and low-volume production [11]. FDM (Fused Depositing Material) is one of the methods used in the 3D printing process by feeding thin filaments into the machine, melting them at the nozzle head, and pushing them out with a thickness of usually 0.25 mm [10], [12]. The nozzle head can move within 3 degrees of freedom (DoF) to deposit the extruded polymer on the platform according to the G code instructions [13]. The FDM method is the most developed system and it is quite easy, although it is difficult to understand since contains many complex process parameters [9], [14]. However, this method is the most progressive for producing a complex prototype and product in low and medium groups [13].

The application of the FDM method for pattern-making using a 3D printer produces patterns with good geometry and accuracy [9]. Both lead time for manufacturing and costs are drastically reduced by this method. Complex shapes can also be obtained easily with higher accuracy and better surface finish [7]. This research focuses on the application of the FDM 3D printing method to make plate patterns in sand casting which is the most popular in foundry and efficient for making small and medium-sized parts since provides good part properties [15]. The use of the plate pattern is in line with the sand casting method where this pattern is suitable for mass production of small object castings [1].

## 2. Method

The manufacturing of plate patterns consists of 3 steps. The first step is designing patterns and core box patterns with CAD application which is then converted into STL format. The second step is to import the design in STL format to the slicer application to set up the parameters of the 3D printer. Next, the patterns and core box are used to make sand moulding which is then poured by molten aluminum. The core box is used to make a sand core on the product with a hole. Last, the third step is to evaluate the plate patterns by analyzing the casting product.

The patterns were printed on an FDM 3D printer i3 Mega S series using a 1.75 mm diameter eSUN PLA+ (polylactic acid) filament. Ultimaker Cura application 4.13.1 series was used as a slicer to transfer the pattern design into G codes. PLA is a biodegradable thermoplastic aliphatic polyester material with a molecular structure  $(C_3H_4O_2)_n$  made from renewable materials such as cornmeal, tapioca, or sugarcane [9]. PLA+ filament is a type of PLA high-version with more advantages and higher quality than the standard filament [16]. The printed pattern was assembled onto a wood plate and then finished to smooth the surface. After that, the plate pattern was used to make sand moulding and molten aluminium was poured into the mould cavity.

The casting product was analyzed to determine the validity of the plate pattern. The data collected are the results of measuring patterns and casting objects using calliper Mitutoyo with an accuracy of 0.02 mm. It was measured 3 times at different sections and the average was taken. Fig. 1 shows the design of the intake manifold that was developed by sand casting, while Fig. 2 shows the measurement section of the pattern and casting product. Geometry analysis was also performed by investigating the shape and smoothness of the surface.

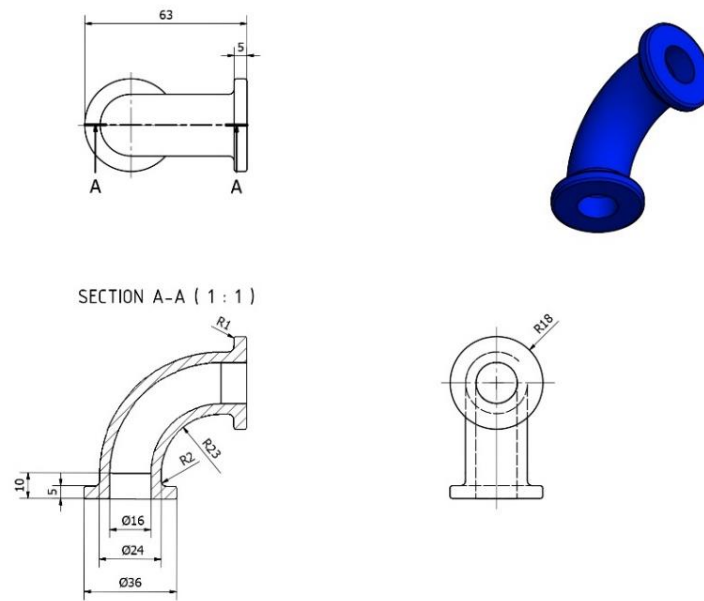

**Fig. 1.** Design of the intake manifold

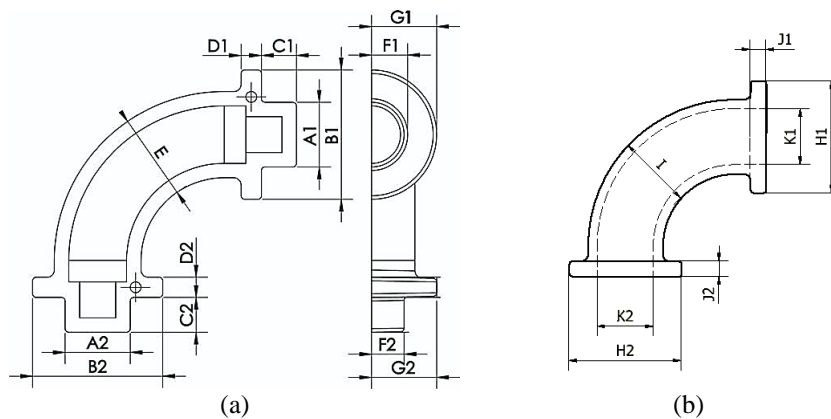

**Fig. 2.** Measurement section on (a) Pattern; (b) Casting product.

### 3. Results and Discussion

The intake manifold pipe was used as an example product in this study because it cannot be produced by conventional machining with a low level of complexity and simple geometry. The hollow shape of the manifold makes the casting process require a core. Therefore, a core box was needed to make the sand core. Steps to make patterns and core box patterns were designing patterns and core box patterns as can be seen in Fig. 3, identifying design patterns, and converting from CAD format (IPT) to STL format with the unit in millimetres and high resolution (Fig. 4). After converting the design to STL format, it is imported into the slicer application Ultimaker Cura application 4.13.1 series. However, the application must be set with a printer that will be used which is Anycubic i3 Mega S/Pro and PLA+ eSUN filament. The printing parameter setting is shown in Table 1 with the control parameter shown in Table 2. The design of the pattern and core box pattern were imported into the application and sliced to get a G code used as a printing command on the FDM 3D printer.

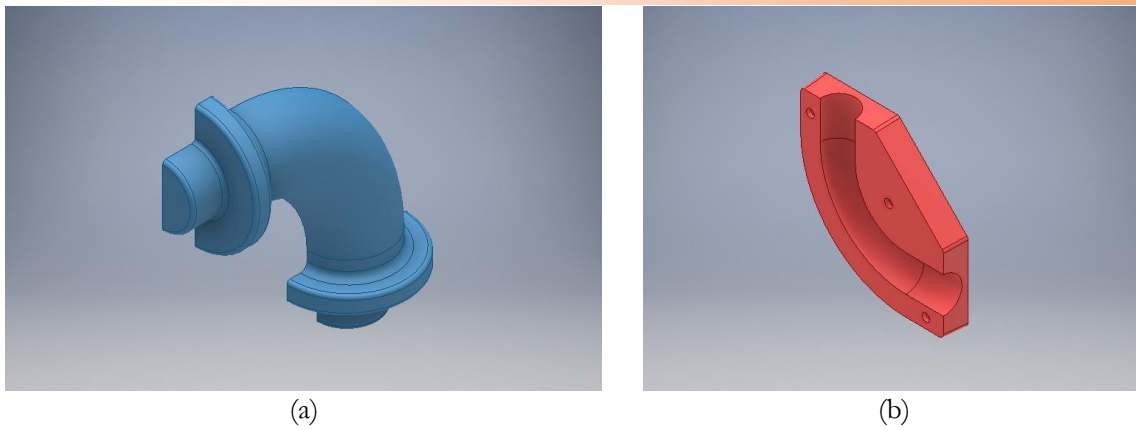

Fig. 3. Pattern design of (a) Intake manifold; (b) Core box

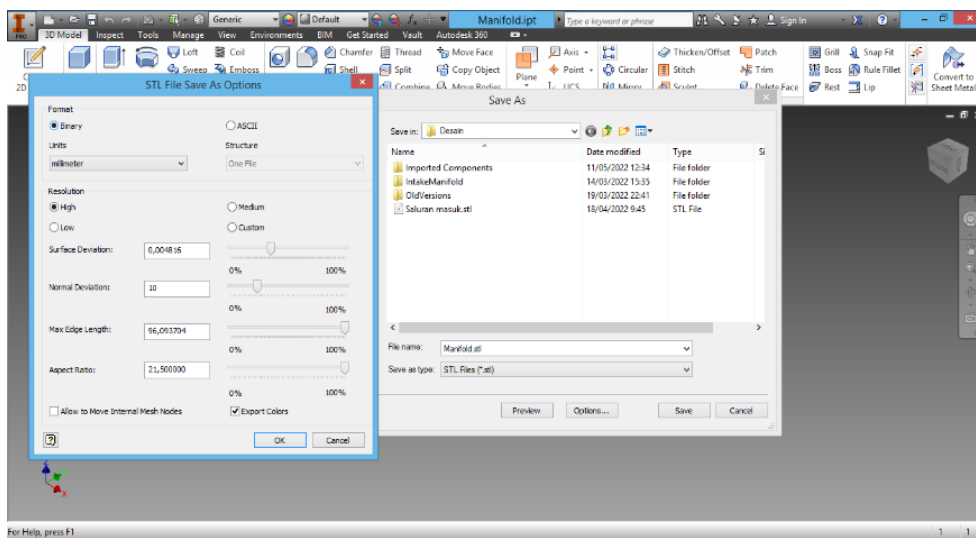

Fig. 4. Converting from IPT format to STL format

Table 1. Pattern printing parameter

Print Trial	Layer Height (mm)	Wall Thickness (mm)	Top/Bottom Thickness (mm)	Printing Temperature (°C)	Print Speed (mm/s)	Fan Speed (%)	Generate Support	Initial Layer Line Width (%)	Enable Ironing
1	0.2	1.2	1.3	205	50	70	Yes	100	Yes
2	0.2	1.2	1.3	215	50	70	Yes	100	Yes
3	0.12	0.8	0.61	205	50	100	No	120	No
4	0.12	0.8	0.61	205	65	100	No	120	No

Table 2. Controlled printing parameter

Infill Density (%)	Build Plate Temperature (°C)	Material Flow (%)
30	60	100

The first print trial shows that the pattern was printed for 4 hours 36 minutes with an estimation of 2 hours 26 minutes. On the second trial, the pattern was printed for 4 hours 42 minutes with an estimation of 2 hours 27 minutes. Furthermore, the third trial shows that the pattern was printed for 3 hours 30 minutes with an estimation of 2 hours 9 minutes. On the fourth trial, the pattern was printed for 2 hours

30 minutes with an estimation of 1 hour 52 minutes. The pattern geometry is shown in Fig. 1 with pattern measurement results shown in Table 1.

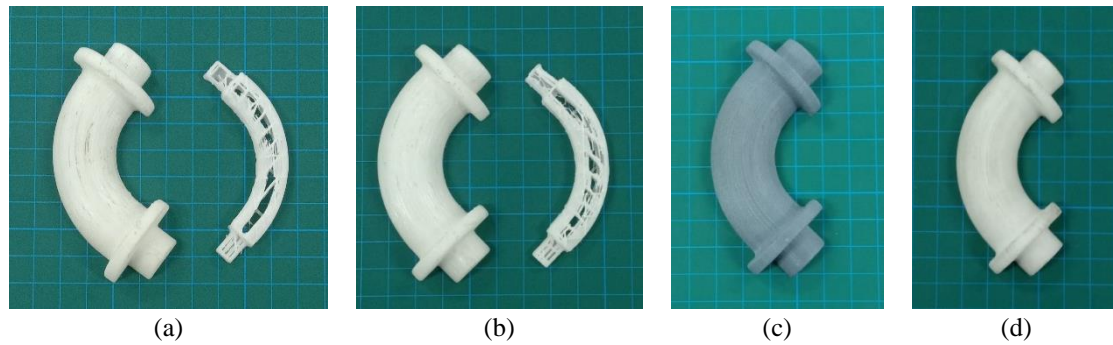

**Fig. 1.** Pattern printout results of (a) Trial 1; (b) Trial 2; (c) Trial 3; (d) Trial 4

**Table 1.** Pattern measurement

Section	Design dimension (mm)	Trial 1		Trial 2		Trial 3		Trial 4		
		Measurement (mm)	Gap Measurement (mm)	Measurement (mm)	Gap Measurement (mm)	Measurement (mm)	Gap Measurement (mm)	Measurement (mm)	Gap Measurement (mm)	
A	1	18	18.027	0.027	18.027	0.027	18.200	0.200	18.220	0.220
	2	18	18.093	0.093	18.040	0.040	18.200	0.200	18.220	0.120
B	1	36	35.840	-0.160	35.880	-0.120	35.873	-0.127	35.867	-0.133
	2	36	35.747	-0.253	36.000	0.000	35.957	-0.047	36.040	-0.040
C	1	10	9.967	-0.033	9.873	-0.127	9.927	-0.073	9.680	-0.020
	2	10	9.920	-0.080	9.773	-0.227	9.927	-0.073	9.827	0.127
D	1	5	5.133	0.133	5.207	0.207	5.027	0.027	5.093	0.093
	2	5	5.160	0.160	5.153	0.153	5.080	0.080	5.060	0.060
E	1	24	24.047	0.047	24.113	0.113	24.153	0.153	24.120	0.120
	2	24	23.960	-0.040	23.900	-0.040	24.113	0.113	23.980	-0.020
	3	24	23.980	-0.020	24.076	0.073	24.093	0.093	24.107	0.107
F	1	9	9.00	0.000	8.933	-0.067	8.980	-0.020	9.000	0.000
	2	9	8.967	-0.033	9.147	0.147	9.007	0.007	8.860	-0.140
G	1	18	17.980	-0.020	18.087	0.087	18.000	0.000	17.933	-0.067
	2	18	17.940	-0.060	17.987	-0.013	17.953	-0.047	17.973	-0.027
H	1	12	11.912	-0.087	11.960	-0.040	11.907	-0.093	11.900	-0.100

Observation in Table 3 shows the differences between the gap and filament layer height is approximately the same. Further observation shows that in sections A, B, C, D, and E which are on the X and Y axis (horizontal), the pattern dimension is increasing. On the other hand, in sections F, G, and H which are in the Z axis (vertical), the pattern dimension is reduced. This is caused by shifting and downward pressure since the printing process is done from the bottom to the top [9]. Based on the result of all trials, the fourth trial gives the best geometry. It has a good surface and an average gap below the layer height. So, the parameter set up for the fourth trial is used to print the mirror of the pattern and

core box pattern. This mirror pattern was printed for 2 hours 38 minutes with an estimation of 1 hour 51 minutes. The pattern geometry is shown in Fig. 6 and measurement results are shown in Table 4.

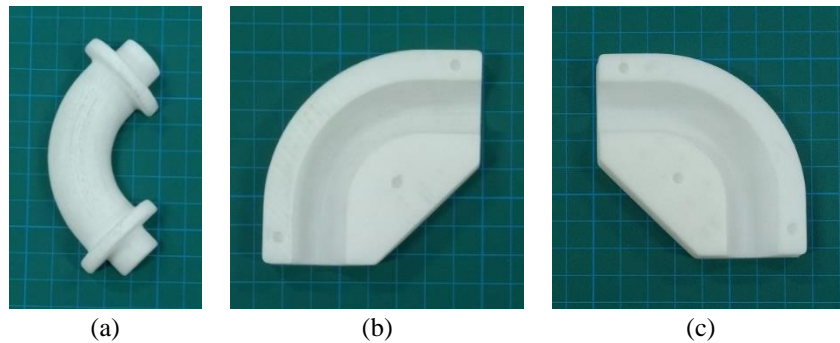

**Fig. 2.** (a) Printout of mirror pattern of the fourth trial; (b,c) Printout of the core box

**Table 2.** The measurement result of the mirror pattern shown in Fig. 6a

Section		Design dimension (mm)	Measurement (mm)	Gap (mm)
A	1	18	18.266	0.260
	2	18	18.293	0.293
B	1	36	35.940	-0.060
	2	36	36.020	0.020
C	1	9.7	9.987	0.287
	2	9.7	9.980	0.280
D	1	5	5.020	0.020
	2	5	5.013	0.013
E	1	24	24.193	0.193
	2	24	24.100	0.100
	3	24	24.020	0.020
F	1	9	8.847	-0.153
	2	9	9.000	0.000
G	1	18	17.987	-0.013
	2	18	17.967	-0.033
H	1	12	11.900	0.100

The pattern and its' mirror that has been printed and then assembled onto the plate of wood with a thickness of 5 mm as shown in Fig. 7. Meanwhile, the printed core box pattern was used to make sand moulding and poured by aluminium to produce the core box. It was used to make a sand core. This core was made by inserting the resin sand into a core box, and then heating it until became hard and turns yellow as can be seen in Fig. 8. However, the printed pattern still needs to be thinly caulked in order to smooth the surface.





**Fig. 3.** Assembled patterns in wood plate

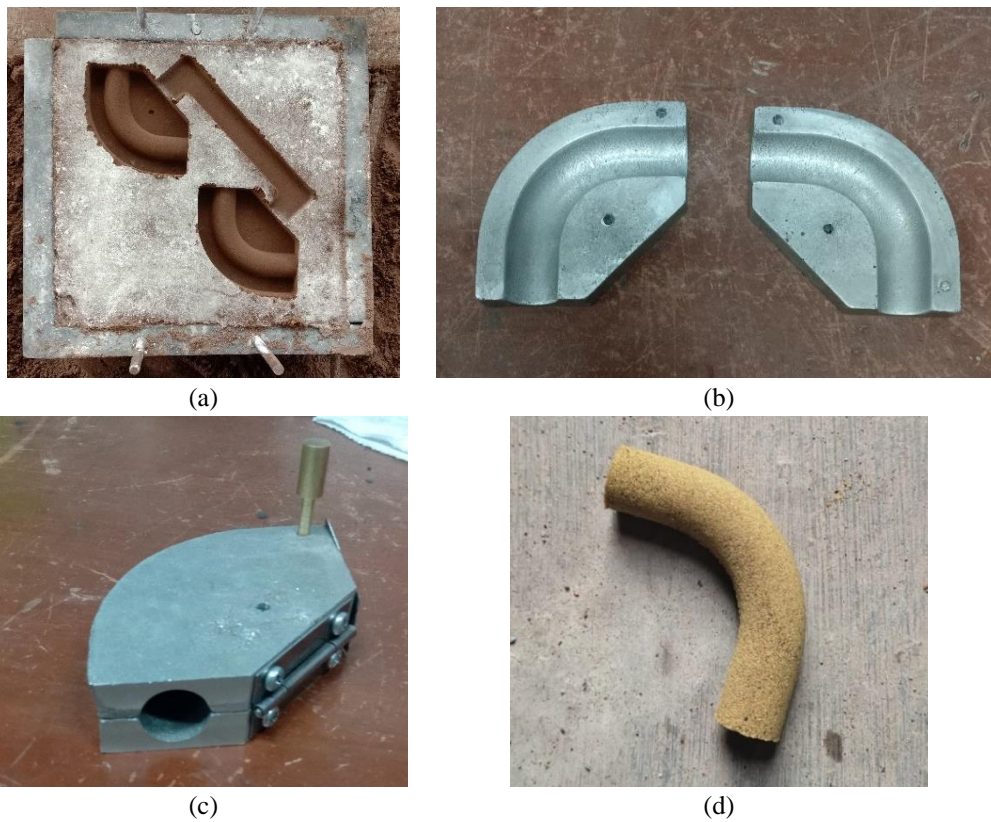
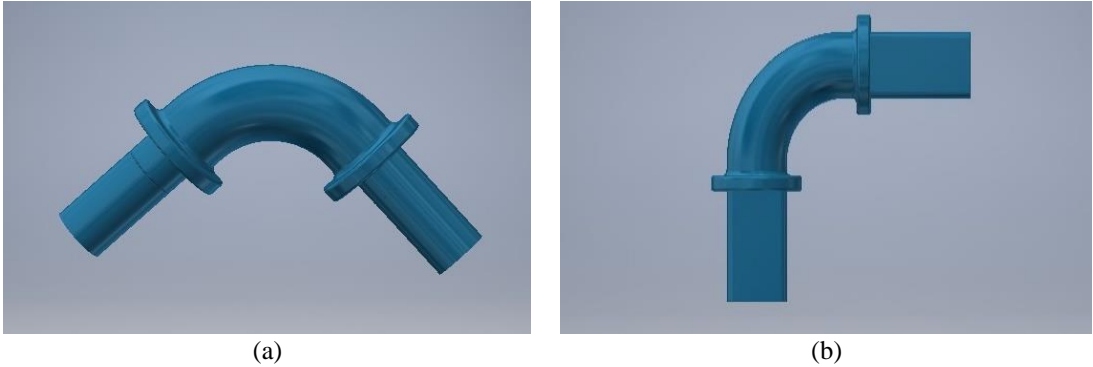

**Fig. 4.** (a) Sand moulding of a core box; (b) Core box castings results; (c) Final core box; (d) Sand core

The sand moulding of the intake manifold was made using the plate pattern shown in Fig. 7. The Sand core that has been made in Fig. 8 was used to make the hollow of the intake manifold. Fig. 9 shows the placement sand core on the sand moulding of the intake manifold. It can be seen that the sand core falls into a mould cavity. It can be seen that the sand core falls into the mould cavity. This is because the sand core weight in the mould cavity is heavier than the sand core weight on the core prints. Therefore, the intake manifold and core box need to be revised. The revision was made by balancing the sand core weight on the cavity and core print parts. This was done by elongating the core print both on the pattern and core box. Besides being elongated, the shape of the drag section changed into rectangular. The changes design of the pattern can be seen in Fig. 10, while the core box is in Fig. 11.



**Fig. 5.** (a) Sand molding; (b) The sand core fall into sand cavity



**Fig. 6.** Revision of patterns on (a) Cope; and (b) Drag.

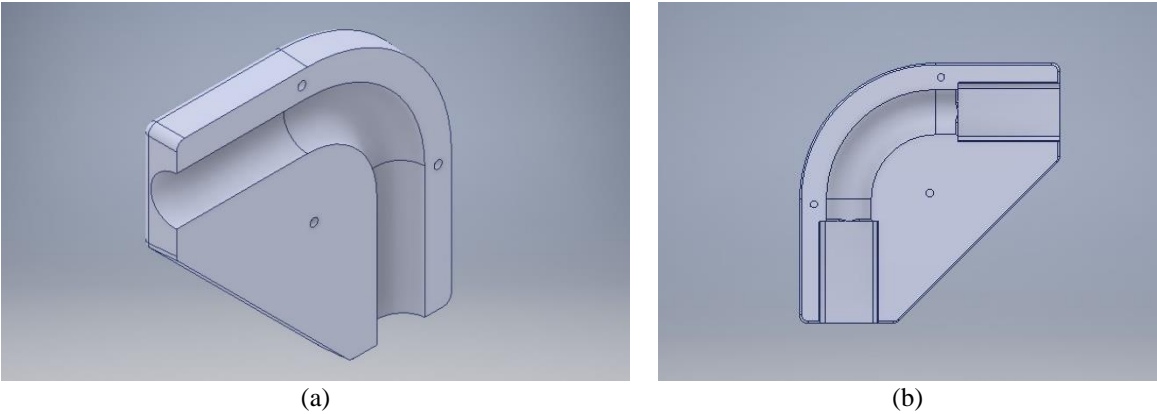

**Fig. 7.** Revision of core box patterns on (a) Cope; and (b) Drag.

The revised design on Fig. 10 and 11 was then saved into STL format. Revision of the pattern was only printing the rectangular shape on the part of the core print and then it was attached to the plate on the drag section as shown in Fig. 12. However, the core box reprinted completely with the same parameter printing of the fourth trial. The core box that has been revised and reprinted was then used to make sand moulding and poured molten aluminium to make a new core box. It is used to make new sand core as can be seen in Fig 13.

The revised plate pattern was tried to make sand mould. The sand core was made from a revised core box placed onto core prints of the sand moulding. Fig. 14 shows that the sand core did not fall into



the sand mould cavity. So that this sand mould can be poured by molten aluminium to obtain the casting product of the intake manifold as shown in Fig. 15. The Finishing process is required for the intake manifold produced by casting. The finished product was then measured on a certain section as shown in Fig. 2b. using a Mitutoyo caliper with an accuracy of 0.02 mm to analyze its dimension. Measurement was conducted 3 times at each section and then the average was taken. Table 5 shows the measurement result.

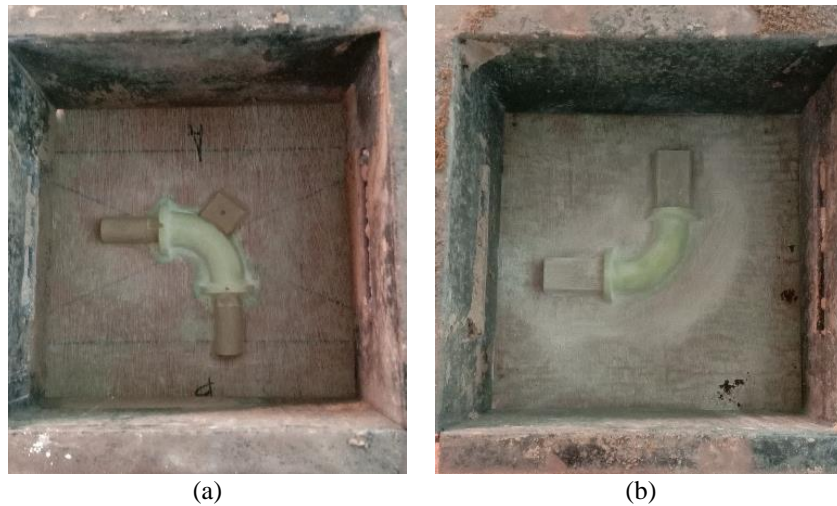

**Fig. 8.** Pattern revision on (a) Cope; and (b) Drag



**Fig. 9.** (a) Core box revision and (b) Revised sand core

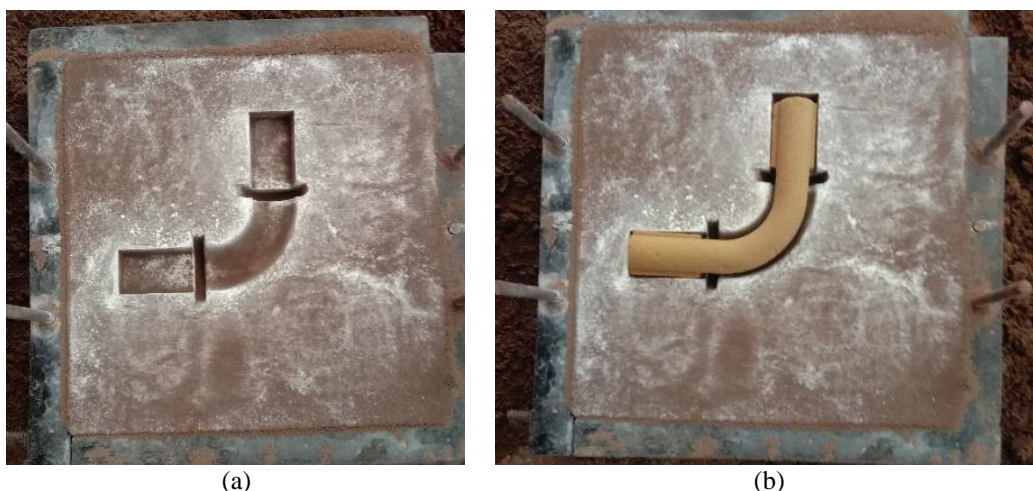

**Fig. 10.** (a) Sand mold after pattern revised; (b) Placement of sand core after revised



**Fig. 11.** Casting product

**Table 3.** Measurement of casting product

Section		Design dimension (mm)	Measurement (mm)	Gap (mm)	Shrinkage (%)
H	1	36	35.547	0.453	1.259
	2	36	35.573	0.427	1.185
I	1	24	23.800	0.200	0.833
J	1	5	5.000	0.000	0.000
	2	5	4.987	0.013	0.267
K	1	18	18.127	-0.127	-0.704
	2	18	18.147	-0.147	-0.815

Table 5 shows that the largest shrinkage of the casting product is 0.453 mm (1.258 %). This is within the allowed tolerance. Most aluminium alloys shrink by 6% by volume during solidification [17]. Table 5 shows that the largest shrinkage of the casting product is 0.453 mm (1.258 %). This is within the allowed tolerance. Most aluminium alloys shrink by 6% by volume during solidification. Furthermore, the dimension of section K is larger than the design. This was due to the dimension of the sand core that was related to the dimension of the core box. However, the core box dimension was not analyzed since it was not the focus of this study.

#### 4. Conclusion

FDM method of the 3D printing technology is feasible to be applied in pattern making on sand casting process. According to the study result, the printing parameter on the slicer application Ultimaker Cura application 4.13.1 series was layer height of 0.12 mm, wall thickness of 0.8 mm, top/bottom thickness of 0.61 mm, printing temperature of 205 °C, printing speed of 65 mm/s, fan speed of 100 %, no generate support, initial layer line width of 12 %, and no enable iron while the controlled printing parameter was infill density of 30 %, build plate temperature 60 °C, and material flow of 100 %. The pattern dimension deviation and the shrinkage of the casting product are still within the tolerance limit. The largest shrinkage of the casting product is 0.453 mm (1.258%). However, the present study was focused on the use of 3D printing technology of the FDM method without considering the casting parameter process. Furthermore, the slicer application used was not the latest released. The surface of the printed pattern still required caulking to make it smoother although it was thin.

### Acknowledgement

This work was financially supported by the Innovation Group Research, Yogyakarta State University (T/2.26/UN34.15/PT.01.02/2022) and Materials and Processing Laboratory, Department of Mechanical Engineering Education, Faculty of Engineering, Yogyakarta State University.

### References

- [1] T. Surdia and K. Chijiwa, *Teknik pengecoran logam*, 10th ed. Jakarta: Balai Pustaka, 2013.
- [2] A. L. Soemowidagdo, *Pengecoran logam*, 1st ed. Yogyakarta: UNY Press, 2017.
- [3] H. Abdillah, M. Munadi, and N. W. Supriyadi, "Comparison of 3d printer and wood casting pattern," *J. Elektro dan Mesin Terap.*, vol. 6, no. 2, pp. 70–80, 2020, [Online]. Available: <https://jurnal.pcr.ac.id/index.php/elementer/article/view/3636>
- [4] D. Pal and B. Ravi, "Rapid tooling route selection and evaluation for sand and investment casting," *Virtual Phys. Prototyp.*, vol. 2, no. 4, pp. 197–207, 2007, doi: 10.1080/17452750701747088.
- [5] S. R. Sama, G. Manogharan, and T. Badamo, "Case studies on integrating 3d sand-printing technology into the production portfolio of a sand-casting foundry," *Int. J. Met.*, vol. 14, no. 1, pp. 12–24, 2020, doi: 10.1007/s40962-019-00340-1.
- [6] P. N. Hasluck, "The pattern maker's handybook: A practical on patterns for founders'," in *Handybooks for Handicrafts*, London: Crosby Lockwood and Son, 1887. [Online]. Available: [https://www.forgottenbooks.com/download\\_pdf/The\\_Pattern\\_Makers\\_Handybook\\_A\\_Practical\\_on\\_Patterns\\_for\\_Founders\\_1000021830.pdf](https://www.forgottenbooks.com/download_pdf/The_Pattern_Makers_Handybook_A_Practical_on_Patterns_for_Founders_1000021830.pdf).
- [7] C. Mendonsa and V. D. Shenoy, "Additive manufacturing technique in pattern making for metal casting using fused filament fabrication printer," *J. Basic Appl. Eng. Res.*, vol. 1, no. 1, pp. 10–13, 2014, [Online]. Available: <http://www.krishisanskriti.org/jbaer.html>
- [8] American Foundrymen's Society, *Patternmaker's manual*, 1st ed. Chicago, IL: American Foundry Society, 1953.
- [9] H. Abdillah and U. Ulikaryani, "Aplikasi 3D printer fused deposite material (fdm) pada pembuatan pola cor," *SINTEK J. J. Ilm. Tek. Mesin*, vol. 13, no. 2, p. 110, 2019, doi: 10.24853/sintek.13.2.110-115.
- [10] J. Kang and Q. Ma, "The role and impact of 3D printing technologies in casting," *China Foundry*, vol. 14, no. 3, pp. 157–168, 2017, doi: 10.1007/s41230-017-6109-z.
- [11] B. Redwood, F. Schöffner, and B. Garret, *The 3d printing handbook: Technologies, design and applications*, 1st ed. Amsterdam, The Netherlands: 3D Hubs B.V., 2017.
- [12] K. V. Wong and A. Hernandez, "A review of additive manufacturing," *ISRN Mech. Eng.*, vol. 2012, pp. 1–10, 2012, doi: 10.5402/2012/208760.
- [13] F. M. Mwema and E. T. Akinlabi, "Basics of fused deposition modelling (fdm)," in *Fused Deposition Modeling*, Springer Cham, 2020, pp. 1–15. doi: 10.1007/978-3-030-48259-6\_1.
- [14] M. Domingo-Espin, J. M. Puigoriol-Forcada, A.-A. Garcia-Granada, J. Llumà, S. Borros, and G. Reyes, "Mechanical property characterization and simulation of fused deposition modeling polycarbonate parts," *Mater. Des.*, vol. 83, pp. 670–677, 2015, doi: 10.1016/j.matdes.2015.06.074.
- [15] C. Sithole, K. Nyembwe, and P. Olubambi, "Process knowledge for improving quality in sand casting foundries: A literature review," *Procedia Manuf.*, vol. 35, pp. 356–360, 2019, doi: 10.1016/j.promfg.2019.05.052.
- [16] B. O'Neill, "PLA vs PLA+: What are the differences and which FDM filament should you buy?," 2021. <https://www.wevolver.com/article/pla-vs-pla-what-are-the-differences-and-which-fdm-filament-should-you-buy> (accessed Jul. 26, 2022).
- [17] P. Kannan and K. Balasubramanian, "Analysis of crown shrinkage in gravity die cast aluminium alloy LM 13 piston," *Indian J. Sci. Technol.*, vol. 8, no. 35, pp. 1–6, 2015, doi: 10.17485/ijst/2015/v8i35/80092.